

The Flostat can be supplied for remote operation by the addition of a pneumatic, electric or electro-pneumatic actuator. The facility allows integration into process controls such as temperature, level, ph, batch measurement etc.

ENQUIRIES

When placing an enquiry, please give all possible details as the manufacturers have great accumulated experience in this specialised field and could contribute valuable guidance. Certainly do not omit to specify the following:-

- Pipe size
- Preferred Materials and Connections
- Control Setting and if adjustment required
- Pressure conditions upstream and downstream
- Fluid including SG and viscosity if unusual, with temperature

INSTALLATION

Each Flostat is calibrated with a straight approach pipe and spring housing vertical. To reproduce the factory calibration precisely, the installation should be similar, however, the friction with the butterfly spindle at other attitudes is extremely small.

The Flostat should be orientated so that sludge does not accumulate in the pressure responsive housing. With liquid flows, it is desirable that the controller does not fill with air when liquid flow stops.

CALIBRATION

For permanent and accurate control, it is only necessary to ensure that the available pressure does not fall below the Threshold Value which is the minimum required to provide the control force and to overcome friction losses (P1-P3).

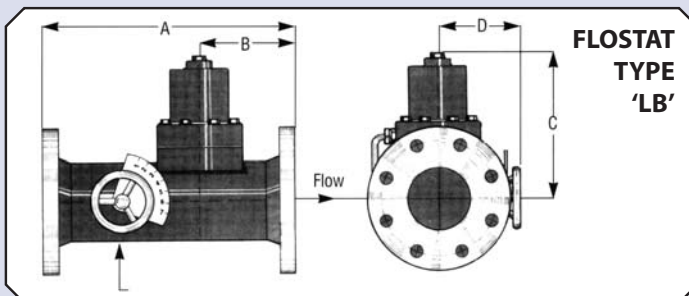
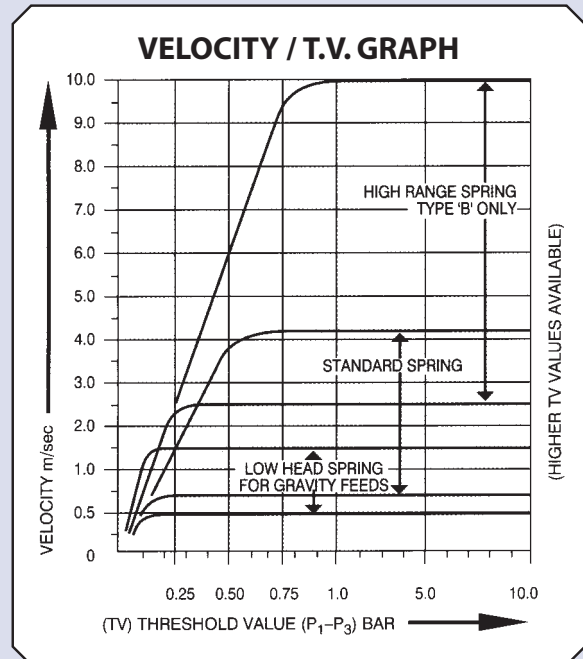

FLOSTAT
TYPE
'LB'

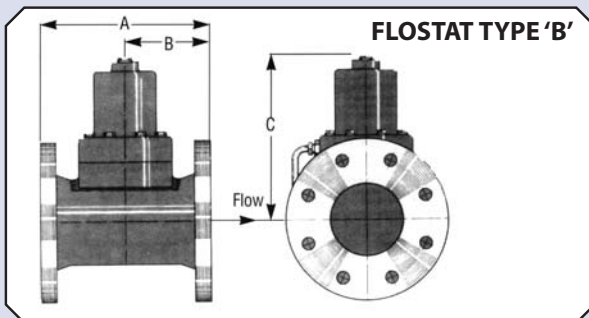

FLOSTAT TYPE 'B'

DIMENSIONS TYPE 'B'

	in's	mm	in's	mm	in's	mm	in's	mm	in's	mm
Size	2	50	2½	65	3	80	4	100	6	150
A	10½	267	10½	267	10½	267	11	279	13	330
B	5½	133	5½	133	5½	133	5½	139	6	152
C	8½	216	8½	216	8½	222	9½	235	15	381

Note: Certain models built for aviation fuel control have smaller axial dimensions.

WEIGHT IN KG

in's	mm	'B'	'LB'
2	50	12	14
2½	65	15	17
3	80	19	22
4	100	25	30
6	150	41	N/A

DIMENSIONS TYPE 'LB'

	in's	mm	in's	mm	in's	mm	in's	mm
Size	2	50	2½	65	3	80	4	100
A	13½	343	13½	343	14	356	15½	394
B	5½	133	5½	133	5½	146	5½	149
C	8½	216	8½	222	8½	222	9	229
D	4½	120	5½	133	5½	133	5½	146

Every effort has been made during the preparation of this document to ensure the accuracy of statements and specifications. However, we do not accept liability for damage, injury, loss or expense caused by errors or omissions made. We reserve the right to withdraw or amend products or documentation without notice.



CT PLATON SAS
 2, rue du Plant Loger
 95330 Domont, France
 Tel : +33 (0)139 354 400
 Fax : +33 (0)139 354 401
 Email : sales@ctplaton.com
 Web : www.ctplaton.com



CERTIFICATE No. FM22358

Automatic Flow Controller

FLOSTAT TYPES B & LB

An automatic flow control valve and governor to limit the maximum rate of liquid flow in a pipe - irrespective of pressure changes - whilst presenting the minimum resistance to normal flow.

FEATURES

- Automatic - no power required
- High accuracy - balanced control valve
- Fast response - short feedback path
- Simple and reliable

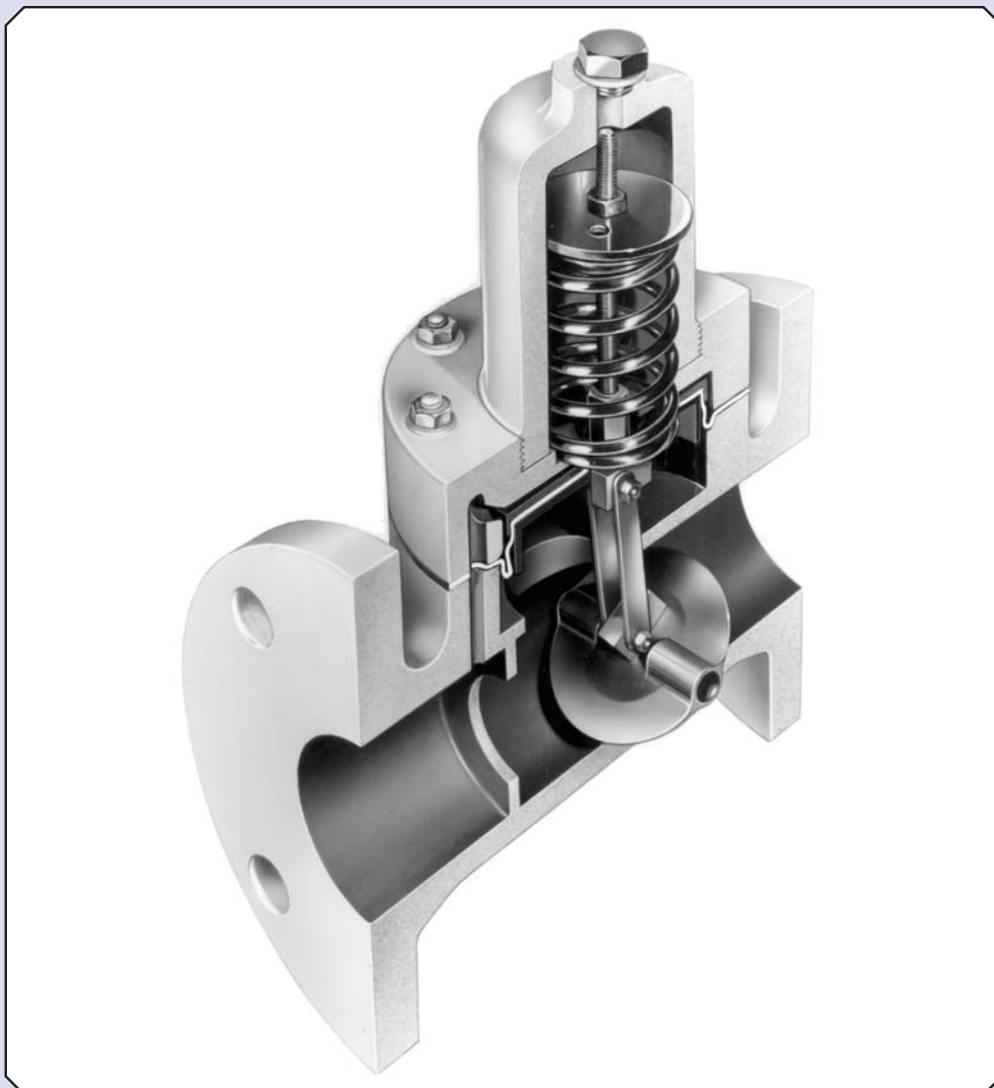

FLOSTAT TYPES B AND LB

Automatic Self-Acting
Flow Control Valve and Governor for 2" – 6" pipes
(50mm – 150mm)

Type B units are factory set for a user defined flow rate.

Type LB units control at a flow rate adjustable over a 6:1 flow range using the external hand wheel.

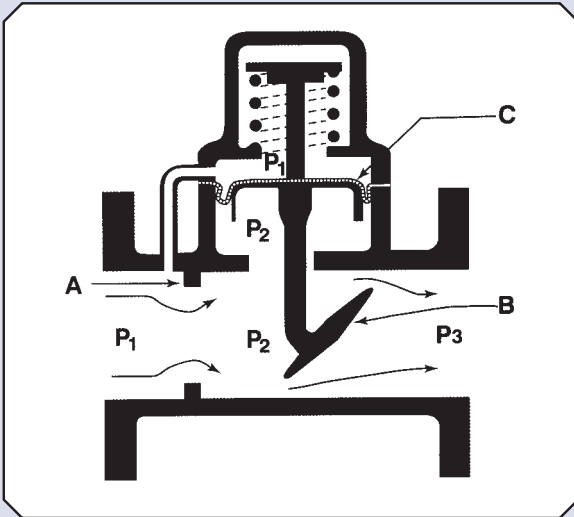

SPECIAL MODELS

- High Pressure
- Pneumatic or electrically-operated set point adjustment of Type LB
- Irrigation Model with special materials and features
- Aviation kerosene units with special shorter overall length
- Different flow ranges

OTHER TYPES OF FLOSTAT

- Type MN in Brass or Stainless Steel for 1/4" pipe, on liquids or gases (see DS1511)
- Type V Flostat for variable flow control of gases, liquids or steam on 1/2" – 4" line sizes (see DS1521)

STANDARD SPECIFICATION

Body	Mild Steel Epoxy Coated or Stainless Steel
Valve Trim	Stainless Steel
Diaphragm	Nitrile, Viton or Stainless Steel bellows
Connections	Flanged to BS, DIN or ASA standards
Control Accuracy	±5%
Reproducibility	±2%
Maximum Temperature	Nitrile and Viton 80°C Stainless Steel bellows 190°C
Maximum Threshold Valve	See Table
Maximum Pressure	20 bar
Hydraulic Test Pressure	25 bar on request

PRINCIPLE

The Flostat combines, in one body, a flow measuring orifice (A) and a balanced control valve (B). The pressure difference $P_1 - P_2$ produced at the orifice acts on a pressure responsive element (C), deflects the control spring and positions the butterfly control valve. At a certain load, $P_1 - P_3$, the equilibrium of force between the diaphragm thrust and the return spring exists at the required flowrate. If the load $P_1 - P_3$ changes, the valve will be moved to a new position so as to produce the necessary compensation to restore the original flowrate and retain the same $P_1 - P_2$ value. The Flostat LB unit also has an external handwheel to adjust the orifice size, which changes the controlled flow value, as shown on a calibrated scale plate.

FLOW RANGES - m³/hr Water 20°C

Size		Type B Fixed Setting Limits			Type LB Variable Setting	Max. Standard Pressure Drop Bar
inches	mm	Low Head	Standard	High		
2	50	2-10	4-30	20-60	4-30	10.5
2½	65	5-15	6-40	30-100	6-40	10.5
3	80	8-20	10-60	40-140	10-60	7
4	100	12-40	20-100	60-200	20-100	5.5
6	150	30-90	60-220	140-240	N/A	5
		Note 1	Note 2			

Note 1: Adjustment of ±10% of Factory setting can be achieved under No Flow conditions

Note 2: Adjustment of ±25% of Factory setting can be achieved under No Flow conditions

FLOSTAT APPLICATIONS

The Flostat brings automation of fluid handling within the reach of industries requiring accurate and reliable control with a substantial cost benefit over the conventional servo-operated control valve. Obvious examples of applications for the Flostat are where:-

- Power is not available
- Control setting is rarely changed
- Installation position is remote or dangerous
- It is necessary to prevent excessive flow
- There is a need to protect machinery and plant
- Long term reliability and high accuracy are required
- Corrosion-resistant and compatible materials are required
- Low pressure drop and high accuracy required

WATER TREATMENT

Flostats are used on Sand Filters and Gravity Filters to overcome vortex flow in the Filter. In the Pre-Coated Filter, it is necessary on initial start-up to have a high flowrate and during normal running reduce to a lower flowrate, which can be achieved by use of a Two-Position Actuator or manual control. Constant flow through a filter ensures smooth cake information and maximum length of life.

IRRIGATION

Flostats limit the flowrate through each outlet, ensuring even distribution and efficient use of the limited supply of water, which is coupled to large seasonal variations.

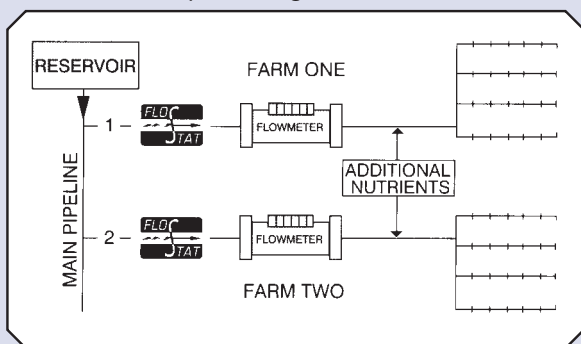

PUMP SAFETY

Flostats prevent overspeed and cavitation when pump supply varies.

DISTRIBUTION & BLENDING OF FLUIDS

Feed from a pump or tank is divided and maintained in correct proportion to any number of requirements and not affected by variations in line pressure. The Flostat ensures maximum efficiency by planned distribution.

COOLING AND CONDITIONING

Flostats are utilised to control the cooling water flow in air conditioning and refrigeration plant to maintain optimum efficiency.

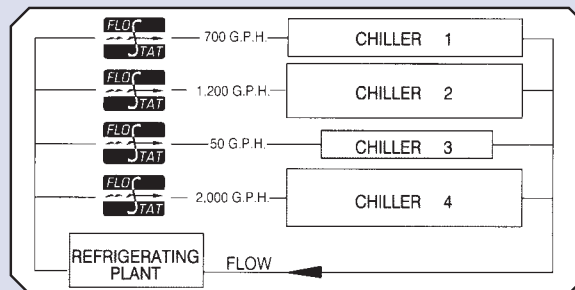

DISTRICT HEATING

For the control of heat distribution by limiting to preset rates, the flow of water in branch loops. A further development is that the Flostat can be adjusted automatically to ensure an adequate temperature drop from "flow" to "return" pipe.

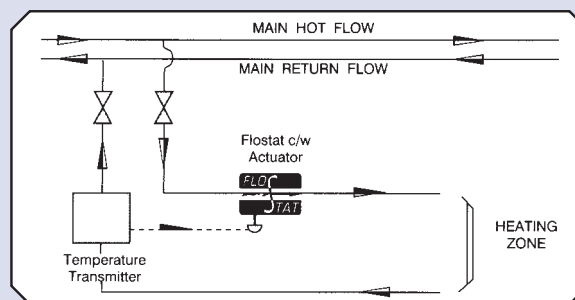

METER PROTECTION

Flostats allow improved pumping economies at oil terminals. Each of the bulk meters is protected from excessive load and overspeeding so that one pump can serve many loading points. A similar unit is utilised to prevent overspeeding of oxygen meters on distribution systems and to minimise the possibility of explosion.

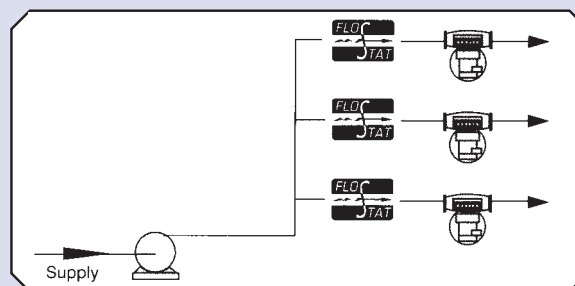

The Flostat has countless applications including:

Absorbers, Aerators, Centrifuges, Chillers, Condensers, Dryers, Evaporators, Extractors, Fermenters, Filters, Heat Exchangers, Homogenisers, Reverse Osmosis, Scrubbers, Softeners, Sprays, Stills

- Blending of Fluids to a fixed formula
- Dispensing of Fluids into accurate fractions
- Chemical reactions where stability is a key factor
- Constant flow on heating or cooling circuits
- Filtration with improved efficiency and filter life
- Protection of equipment from excessive flows
- Burner control providing quick start-up and temperature zoning
- Aggregate particle size separation
- Ratio of powder fluidisation and conveying
- Batch control
- Irrigation