

## Automatic Flow Controller

### FLOSTAT TYPE MN

#### DESCRIPTION

FLOSTATS from Roxspur Measurement & Control are automatic flow control devices for liquids or gases. Once adjusted to the required value, flow is maintained accurately at this rate independent of pressure fluctuations in the supply or varying backpressures downstream of the meter. No electrical power or external flow measurement input is required – the Flostat control system uses the line pressure available.

FLOSTATS are ideal for blending or dosing applications to maintain the required delivery of valuable gases or liquids, despite process line-pressure changes. Similarly, FLOSTATS are ideal for use on gas sampling, purging or inert gas blanketing systems to maintain flow rate independent of back pressure. Bubbler type liquid level measurement systems benefit from improved accuracy and lower gas usage when fitted with a FLOSTAT. To assist in setting the correct flow rate, the Flostat type MN is frequently installed in line with a Platon type GI or GU variable area flowmeter.

#### FEATURES

- Automatic
- No power required
- Adjustable over wide range
- High Accuracy
- Fast response
- Gases or liquids
- Suitable for use on flammable liquids



## PRINCIPLE OF OPERATION

Section diagram

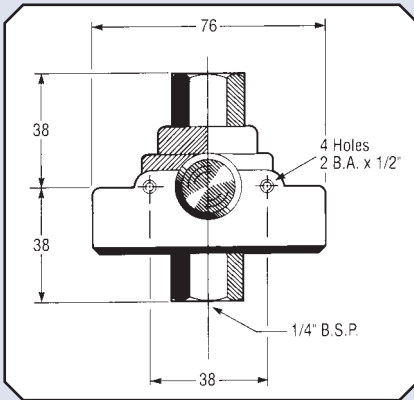

The control valve varies the size of the orifice A. Flow through this orifice produces a pressure difference.  $P_1 - P_2$  which acts across the diaphragm B. This is opposed by the force from the spring C. The diaphragm modulates the flow from the Flostat discharge port, maintaining the internal pressure drop  $P_1 - P_2$  constant and equal to the spring force. This produces a constant flowrate, determined by the orifice size set by the valve.

**For liquids**, the Flostat (Type MNA) will maintain a constant flowrate irrespective of any pressure changes whether up or downstream.

**For gases**, the Flostat can compensate for pressure variations only on one side of the unit, because gas compressibility affects the orifice calibration. **Type MNA** units give a constant flow when the supply pressure is relatively constant - these units compensate for variations in discharge or downstream back pressure. **Type MNB** units are used to maintain constant flow when the supply pressure is varying, but where discharge pressure is relatively constant (eg discharge to atmosphere).

## SPECIFICATION

Models: MN\*B: Brass Polyester coated  
 MN\*S: 316 Stainless steel

	MN*B	MN*S
Diaphragm & Seals	Nitrile	PTFE
Temperature max	80°C	100°C
Pressure max	20 Bar	28 Bar
Max. operating DP	7 bar	
Min. operating DP	See table below	
Connections	1/4 BSP Parallel	
Control Accuracy	±2% liquids, ±3% gases	

## DIMENSIONS

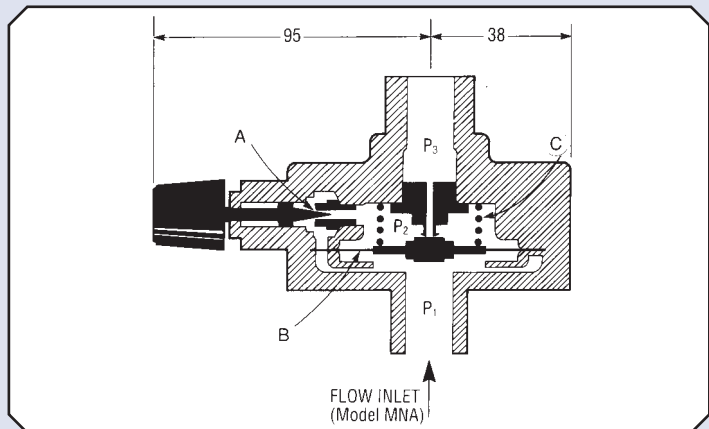

## FLOW RANGES AND MODELS

ORDER CODE		CONTROL RANGE (cm <sup>3</sup> /min)		MINIMUM DP FOR CONTROL
Brass Body	S/S Body	Water (20°C)	Air (ATP)	
MNAB11	MNAS12	2-200	5-5000	0.3 Bar
MNAB21	MNAS22	50-1500	100-30,000	0.7 Bar
MNAB31	MNAS32	250-3500	8000-100,000	2.3 Bar

## Options available

MNBB and MNBS models for gas flow with varying supply pressure. MNT models for higher pressure drops across the diaphragm. MNG models for control with lower DP (down to 0.1 Bar typical). MNX models for high static pressure applications (up to 150 Bar). For larger capacities, 1/2" to 4" line sizes, use Type V Flostats (See leaflet DS1521).

## Installation

Flostats Type MN can be installed in any orientation. Ensure that the flow is in the direction of the arrow on the label. Flostats are suitable for clean dry gases or clean liquids: any particles could restrict the flow through the control office.



0043



CT PLATON SAS  
 Immeuble Le Saint Clair  
 BP70-213  
 42013 Saint Etienne Cédex2  
 France  
 T: 33(0)477 410 688  
 F: 33(0)477 570 421  
 E-Mail : sales@ctplaton.com  
 www.ctplaton.com



CERTIFICATE NO. 22358