

CT PLATON SAS

20 SERIES LEVEL SWITCHES

One-float level switch for side mounting with one or two switching units. For pressure up to 60 Bar, for temperatures of between -10°C and 135°C and for fluids with a specific gravity of 0.6 kg/dm³ min. Minimum differential of each switch with SP.GR. of 1 kg/dm³, 35 mm. Set point accuracy: ± 5 mm.

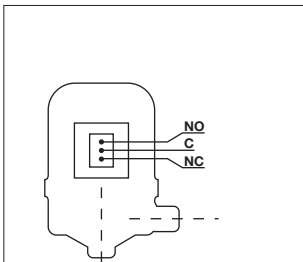

20 series

The **20 series** is equipped with one switching unit fitted with one SPDT switch (two simultaneous acting SPDT switches can be supplied on request)

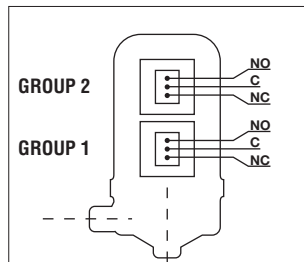

20 D series

The **20 D series** is equipped with two switching units (for separate actions) with one SPDT switch fitted on each unit.

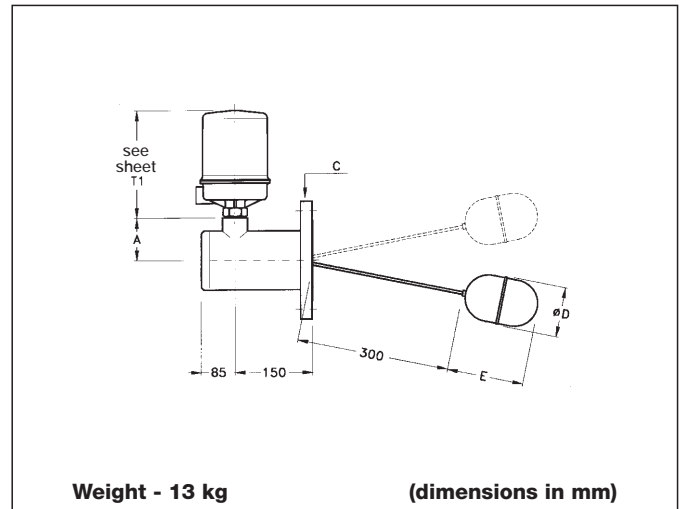
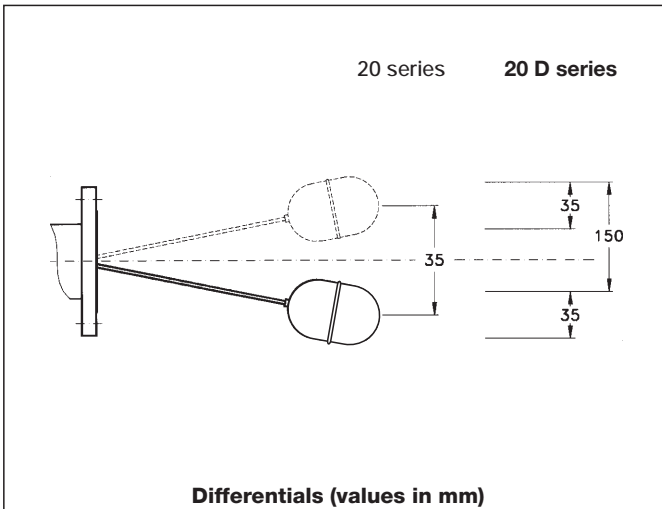

Floats		Minimum specific gravity (2)	STD. Flange connection "C"	A mm
D mm	E mm			
68	120	0,8 kg/dm ³	3"/DN80	70
68	120	0,8 kg/dm ³	4"/ DN100	82
94	140	0,6 kg/dm ³	4"/ DN100	82
94	180 ⁽¹⁾	0,6 kg/dm ³	4"/ DN100	82

(1) Used on model 26 with pressure rating of 60 Bar.
 (2) Refers to STD. switch with 300 mm long rod.

On request, special versions for working at temps. below -10°C and over 135°C can be supplied.

Standard "C" flange connection UNI PN 16 - 40 DN 80 - 100/3" - 4" ANSI 150 - 300RF.

WORKING CONDITIONS

MODEL		22			24			26		
STD "C" FLANGE		3" - 4" ANSI 150 RF UNI DN 80-100 PN 16			3" - 4" ANSI 300 RF UNI DN 80-100 PN 40			4" ANSI 600 RF UNI DN 100 PN 64		
VERSION		A	I	J	A	I	J	A	I	J
Temperatures	38° C	20	19	19	40	40	40	52	50	50
	100° C	17	15	16	35	30	31	46	40	42
	135° C	16	14	15	35	28	29	46	37	39
	BODY RATING	ANSI 150			PN 40			ANSI 300		
		Max pressure in bar								

MATERIALS

CODE FOR	Materials	Carbon steel	AISI 304	AISI 316
	Body	A	I	J
	Float	-	-	2

On request, versions in plastic (PVC - MOPLN - PVDF) can be supplied.

SWITCHES

Type	Mercury switch	Dry microswitch					Pneumatic switch*	
Load rating	220 V a. c. 10 A 110 V d. c. 1,5 A	250 V a. c. 10 A 125 V d. c. 0,5 A	125 V d. c. 10 A	250 V a. c. 10 A 125 V d. c. 0,5 A water-proof IP67	125 V a. c. 1 A 28 V d. c. 1 A water-proof with gold contacts	250 V a. a. 1A 24 V d.c. 5A sealed with inert gas	Output: 0 ÷ 40 psi max.	
CODE	VD	M2	M3	M4	M6	M14	PN brass	PN1 inox

* Air inlet and output connection 1/4" NPT-F - No bleed type

ENCLOSURES

Type	Waterproof	Explosion-proof	The (WP) enclosures can be supplied whit gland or with a 3 or 7 pole connector as per MIL standards. The (EP) enclosures can be supplied whit explosion-proof gland. 1) CESI certificate N. 02-ATEX-126
Material	Aluminium	Aluminium	
Electrical connection	1/2" NPT-F/GAS 3/4" NPT-F/GAS ISO M20X1.5	1/2" UNI 6125/NPT-F 3/4" UNI 6125/NPT-F ISO M20X1.5	
Protection degree	IP 66	1) II 2G EEx-d IIC T6 IP 66	
CODE	WP	EP	

HOW TO ORDER:

Example: 22 - A - 2 - M2 - WP

22 model
A body in carbon steel
2 float in S/steel AISI 316
M 2 dry microswitch 250 V a.c. - 10 A.
WP waterproof enclosure

The following data are required: type of fluid, specific gravity, operating temperature and pressure.

CT PLATON SAS
Immeuble le Saint Clair, BP 70-213
42013 Saint Etienne Cédex 2, France
Tel : 33(0)477 410 688
Fax : 33(0)477 570 421
sales@ctplaton.com - www.ctplaton.com

CT Platon
INSTRUMENTATION

.....